

HL 962

Assembly stand for pumps



The illustration shows a similar unit.

Learning objectives/experiments

- in conjunction with an accessory pump (standard chemicals pump HL 962.01, canned motor pump HL 962.02, side channel pump HL 962.03, standard chemicals pump with magnetic clutch HL 962.04) and a suitable water supply, e.g. HL 962.30 with HL 962.32
 - ▶ mounting of the pump and alignment of the electric motor
 - ▶ familiarisation with various methods of aligning the motor and pump
 - ▶ commissioning and leak testing
 - ▶ recording a pump characteristic
 - ▶ comparison of various pump types (only if multiple pumps are available)

Description

- mounting of different pumps (available as accessories)
- alignment of motor and pump by different methods
- base unit when constructing a complex piping system

The individual steps for repairing driven machines such as pumps are: removal and installation of pumps for inspection, repair or replacement; aligning the drive and commissioning and checking the pump, e.g. for leaks.

In conjunction with the HL 962.30 tank system, the HL 962.32 connecting pipes and one of the four HL 962.01 – HL 962.04 pumps, the HL 962 assembly stand forms a complete training system for complex piping and plant systems. The training system forms a closed water circuit.

The assembly stand HL 962 includes a three-phase asynchronous motor with frequency converter as the drive and pipes with valves to adjust the pressure. A pump from the accessory equipment is attached to the base plate of the assembly stand and connected to the drive and the pipes. The pumps that are available as accessories are typical centrifugal pumps used in process engineering.

The position of the asynchronous motor can be adjusted in three directions for alignment purposes. The alignment can either be checked in a conventional manner with a straight edge or with the reverse alignment method using two dial gauges. Non-contact, microprocessor-aided methods can also optionally be used (specific alignment systems are not included in the scope of delivery).

Manometers indicate the pressures upstream and downstream of the pump. The flow rate is measured with a rotameter. Speed and power output of the motor are indicated on digital displays.

HL 962

Assembly stand for pumps



1 flange connections to connect HL 962 to HL 962.30, 2 switch box with displays and controls, 3 electric motor, 4 mounting plate for test pump, 5 flange connections for test pump, 6 manometer, 7 valve, 8 flow meter

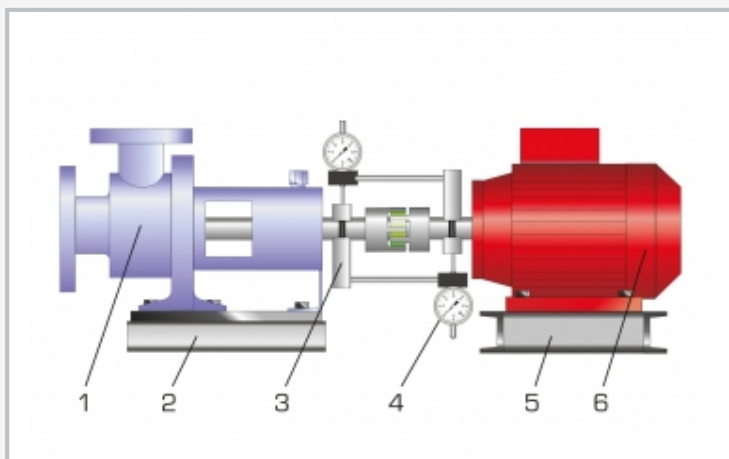

1 HL 962.01 pump, 2 pump base plate, 3 bracket for dial gauge, 4 dial gauge, 5 motor base plate, 6 electric motor

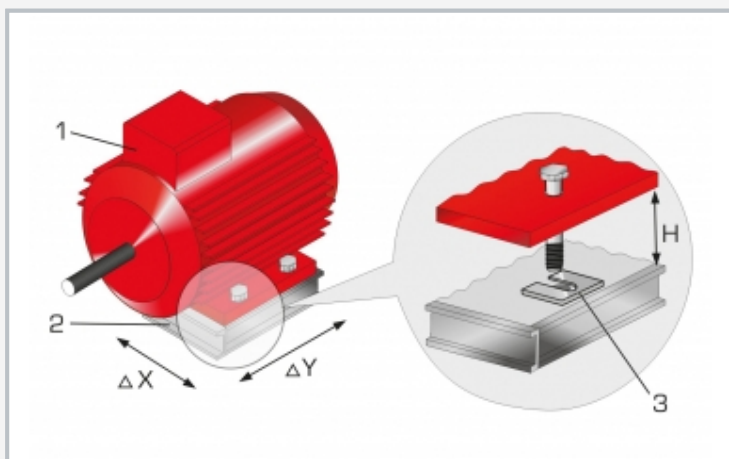

Aligning the electric motor (height, x and y direction): 1 electric motor, 2 base plate, 3 fitting plates to adjust the height H

Specification

- [1] stand for mounting of various pumps
- [2] asynchronous motor with variable speed via frequency converter
- [3] electric motor with positioning frame and fit plates for alignment
- [4] base plate prepared for mounting of various pumps
- [5] alignment of motor and pump with straight-edge or by dial gauges
- [6] switch box with speed adjuster and digital display of speed and power output
- [7] frame with adjustable feet for levelling
- [8] PVC piping
- [9] water supply from tank system HL 962.30
- [10] the system forms part of the GUNT assembly, maintenance and repair practice line

Technical data

Three-phase AC asynchronous motor
 ■ power output: 4kW, speed range: 0...1450min⁻¹

Connecting flanges for water supply

- intake side: DN50
- delivery side: DN50
- intake side channel pump: DN32

Fit plates as motor chocks

- 43x43mm
- 4 different thicknesses: 0,1 - 0,2 - 0,5 - 1,0mm, 20 of each

Measuring ranges

- pressure (inlet): ± 1 bar
- pressure (outlet): 0...16bar
- flow rate: 0...11m³/h
- speed: 0...3000min⁻¹
- power: 0...4kW
- travel: 0...3mm, resolution: 0,01 mm

400V, 50Hz, 3 phases

400V, 60Hz, 3 phases; 230V, 60Hz, 3 phases

LxWxH: 1300x750x1800mm

Weight: approx. 220kg

Scope of delivery

- 1 assembly stand
- 1 set of tools
- 1 set of measuring aids: 2 dial gauges with attachment, 1 straight-edge
- 80 fit plates, differing thicknesses
- 1 set of instructional material

HL 962

Assembly stand for pumps

Required accessories

065.96230	HL 962.30	Tank system
065.96232	HL 962.32	Piping systems and fittings
065.96201	HL 962.01	Standard chemicals pump
or		
065.96202	HL 962.02	Canned motor pump
or		
065.96203	HL 962.03	Side channel pump
or		
065.96204	HL 962.04	Standard chemicals pump with magnetic clutch